

Robert Bosch GmbH
Power Tools Division
70745 Leinfelden-Echterdingen
Germany

www.bosch-garden.com

F 016 L70 877 (2014.02) 0 / 12 XXX



AHS

45-15 LI | 35-15 LI



en Original instructions



English

Safety Notes

Explanation of symbols



Read instruction manual.



Do not expose to rain.



Remove battery before adjusting or cleaning, and before leaving the machine unattended for any period.

General Power Tool Safety Warnings

⚠ WARNING Read all safety warnings and all instructions. Failure to follow the warnings and instructions may result in electric shock, fire and/or serious injury.

Save all warnings and instructions for future reference.

The term "power tool" in the warnings refers to your mains-operated (corded) power tool or battery-operated (cordless) power tool.

Work area safety

- ▶ **Keep work area clean and well lit.** Cluttered or dark areas invite accidents.
- ▶ **Do not operate power tools in explosive atmospheres, such as in the presence of flammable liquids, gases or dust.** Power tools create sparks which may ignite the dust or fumes.
- ▶ **Keep children and bystanders away while operating a power tool.** Distractions can cause you to lose control.

Electrical safety

- ▶ **Power tool plugs must match the outlet. Never modify the plug in any way. Do not use any adapter plugs with earthed (grounded) power tools.** Unmodified plugs and matching outlets will reduce risk of electric shock.
- ▶ **Avoid body contact with earthed or grounded surfaces, such as pipes, radiators, ranges and refrigerators.** There is an increased risk of electric shock if your body is earthed or grounded.
- ▶ **Do not expose power tools to rain or wet conditions.** Water entering a power tool will increase the risk of electric shock.
- ▶ **Do not abuse the cord. Never use the cord for carrying, pulling or unplugging the power tool. Keep cord away from heat, oil, sharp edges and moving parts.** Damaged or entangled cords increase the risk of electric shock.
- ▶ **When operating a power tool outdoors, use an extension cord suitable for outdoor use.** Use of a cord suitable for outdoor use reduces the risk of electric shock.

- ▶ **If operating a power tool in a damp location is unavoidable, use a residual current device (RCD) protected supply.** Use of an RCD reduces the risk of electric shock.

Personal safety

- ▶ **Stay alert, watch what you are doing and use common sense when operating a power tool. Do not use a power tool while you are tired or under the influence of drugs, alcohol or medication.** A moment of inattention while operating power tools may result in serious personal injury.
- ▶ **Use personal protective equipment. Always wear eye protection.** Protective equipment such as dust mask, non-skid safety shoes, hard hat, or hearing protection used for appropriate conditions will reduce personal injuries.
- ▶ **Prevent unintentional starting. Ensure the switch is in the off-position before connecting to power source and/or battery pack, picking up or carrying the tool.** Carrying power tools with your finger on the switch or energising power tools that have the switch on invites accidents.
- ▶ **Remove any adjusting key or wrench before turning the power tool on.** A wrench or a key left attached to a rotating part of the power tool may result in personal injury.
- ▶ **Do not overreach. Keep proper footing and balance at all times.** This enables better control of the power tool in unexpected situations.
- ▶ **Dress properly. Do not wear loose clothing or jewellery. Keep your hair, clothing and gloves away from moving parts.** Loose clothes, jewellery or long hair can be caught in moving parts.
- ▶ **If devices are provided for the connection of dust extraction and collection facilities, ensure these are connected and properly used.** Use of dust collection can reduce dust-related hazards.

Power tool use and care

- ▶ **Do not force the power tool. Use the correct power tool for your application.** The correct power tool will do the job better and safer at the rate for which it was designed.
- ▶ **Do not use the power tool if the switch does not turn it on and off.** Any power tool that cannot be controlled with the switch is dangerous and must be repaired.
- ▶ **Disconnect the plug from the power source and/or the battery pack from the power tool before making any adjustments, changing accessories, or storing power tools.** Such preventive safety measures reduce the risk of starting the power tool accidentally.
- ▶ **Store idle power tools out of the reach of children and do not allow persons unfamiliar with the power tool or these instructions to operate the power tool.** Power tools are dangerous in the hands of untrained users.
- ▶ **Maintain power tools. Check for misalignment or binding of moving parts, breakage of parts and any other condition that may affect the power tool's operation. If damaged, have the power tool repaired before use.**

Many accidents are caused by poorly maintained power tools.

- ▶ **Keep cutting tools sharp and clean.** Properly maintained cutting tools with sharp cutting edges are less likely to bind and are easier to control.
- ▶ **Use the power tool, accessories and tool bits etc. in accordance with these instructions, taking into account the working conditions and the work to be performed.** Use of the power tool for operations different from those intended could result in a hazardous situation.

Battery tool use and care

- ▶ **Recharge only with the charger specified by the manufacturer.** A charger that is suitable for one type of battery pack may create a risk of fire when used with another battery pack.
- ▶ **Use power tools only with specifically designated battery packs.** Use of any other battery packs may create a risk of injury and fire.
- ▶ **When battery pack is not in use, keep it away from other metal objects, like paper clips, coins, keys, nails, screws or other small metal objects, that can make a connection from one terminal to another.** Shorting the battery terminals together may cause burns or a fire.
- ▶ **Under abusive conditions, liquid may be ejected from the battery; avoid contact. If contact accidentally occurs, flush with water. If liquid contacts eyes, additionally seek medical help.** Liquid ejected from the battery may cause irritation or burns.

Service

- ▶ **Have your power tool serviced by a qualified repair person using only identical replacement parts.** This will ensure that the safety of the power tool is maintained.

Hedge trimmer safety warnings

- ▶ **Keep all parts of the body away from the cutter blade. Do not remove cut material or hold material to be cut when blades are moving. Make sure the switch is off when clearing jammed material.** A moment of inattention while operating the hedge trimmer may result in serious personal injury.
- ▶ **Carry the hedge trimmer by the handle with the cutter blade stopped. When transporting or storing the hedge trimmer always fit the cutting device cover.** Proper handling of the hedge trimmer will reduce possible personal injury from the cutter blades.
- ▶ **Hold power tool by insulated gripping surfaces only, because the cutter blade may contact hidden wiring.** Cutter blades contacting a "live" wire may make exposed metal parts of the power tool "live" and could give the operator an electric shock.

Additional safety warnings

- ▶ This tool is not intended for use by persons (including children) with reduced physical, sensory or mental capabilities, or lack of experience and knowledge, unless they have been given supervision or instruction concerning use

of the appliance by a person responsible for their safety. Children should be supervised to ensure that they do not play with the appliance.

- ▶ **When working with the machine, always hold it firmly with both hands and provide for a secure stance.** The power tool is guided more secure with both hands.
- ▶ **Wait until the machine has come to a standstill before placing it down.**
- ▶ Other persons and animals should remain at a distance of 3 metres or more when the machine is being used. The operator is responsible for third persons in the working area.
- ▶ Never grasp the blade of the hedgecutter.
- ▶ Children or persons unfamiliar with these instructions must not operate the hedgecutter. Local regulations may restrict the age of the operator.
- ▶ Never cut a hedge while people, especially children or pets, are nearby.
- ▶ The operator or user is responsible for accidents or hazards occurring to other people or their property.
- ▶ Do not operate the hedgecutter when barefoot or wearing open sandals, always wear substantial footwear and long trousers. The use of sturdy gloves, non-skid footwear and safety glasses is recommended. Do not wear loose clothing or jewellery which can be caught in moving parts.
- ▶ Thoroughly inspect the area where the hedgecutter is to be used and remove all wires and other foreign objects.
- ▶ Prior to operation, check cutter blades, blade bolts and cutter assembly for wear or damage. Do not operate with a damaged or excessively worn cutting device.
- ▶ Know how to stop the hedgecutter quickly in an emergency.
- ▶ Cut a hedge only in daylight or in good artificial light.
- ▶ Never operate the hedgecutter with defective guards or without the guard in place.
- ▶ Always ensure all handles and guards supplied are fitted when using the hedgecutter. Never attempt to use an incomplete hedgecutter or one with an unauthorised modification.
- ▶ Never hold the hedgecutter by the guard.
- ▶ While operating the hedgecutter always be sure of a safe and secure operating position at all times, especially when using steps or a ladder.
- ▶ Always be aware of your surroundings and stay alert for possible hazards that you may not hear whilst operating the hedgecutter.
- ▶ Keep all nuts, bolts and screws tight to ensure that the hedgecutter is always in a safe working condition.
- ▶ The hedgecutter should be stored in a dry, high or locked up place out of the reach of children.
- ▶ Replace worn or damaged parts for safety.
- ▶ Do not attempt to repair the machine unless you are qualified to do so.
- ▶ Ensure replacement parts fitted are Bosch approved.

4 | English

Safety Warnings for Batteries

- ▶ **Do not open the battery.** Danger of short-circuiting.



Protect the battery against heat, e. g., against continuous intense sunlight, fire, water, and moisture. Danger of explosion.

- ▶ **Do not short-circuit the battery.** There is danger of explosion.
- ▶ **In case of damage and improper use of the battery, vapours may be emitted. Ventilate the area and seek medical help in case of complaints.** The vapours can irritate the respiratory system.
- ▶ **If the battery becomes defective, liquid can escape and come into contact with adjacent components. Check any parts concerned.** Clean such parts or replace them, if required.
- ▶ **Use the battery only in conjunction with your Bosch power tool.** This measure alone protects the battery against dangerous overload.
- ▶ **Use only original Bosch batteries with the voltage listed on the nameplate of your power tool.** When using other batteries, e. g. imitations, reconditioned batteries or other brands, there is danger of injury as well as property damage through exploding batteries.

Safety Warnings for Battery Chargers

Keep the battery charger away from rain or moisture. Penetration of water in the battery charger increases the risk of an electric shock.



- ▶ **Do not charge other batteries.** The battery charger is suitable only for charging Bosch lithium ion batteries within the listed voltage range. Otherwise there is danger of fire and explosion.
- ▶ **Keep the battery charger clean.** Contamination can lead to danger of an electric shock.
- ▶ **Before each use, check the battery charger, cable and plug. If damage is detected, do not use the battery charger. Never open the battery charger yourself. Have repairs performed only by a qualified technician and only using original spare parts.** Damaged battery chargers, cables and plugs increase the risk of an electric shock.
- ▶ **Do not operate the battery charger on easily inflammable surfaces (e. g., paper, textiles, etc.) or surroundings.** The heating of the battery charger during the charging process can pose a fire hazard.
- ▶ **Supervise children.** This will ensure that children do not play with the charger.
- ▶ **Children or persons that owing to their physical, sensory or mental limitations or to their lack of experience or knowledge, are not capable of securely operating the charger, may only use this charger under supervision or after having been instructed by a responsible person.** Otherwise, there is danger of operating errors and injuries.

Maintenance

- ▶ **Remove battery before adjusting or cleaning, and before leaving the machine unattended for any period.** Always wear gardening gloves when handling or working near the sharp blades.
- ▶ Examine the machine and replace worn or damaged parts for safety.
- ▶ Always lubricate the cutting blade with protective spray before storage.
- ▶ Keep all nuts, bolts and screws tight to be sure that the machine is in safe working condition.
- ▶ Ensure replacement parts fitted are Bosch approved.
- ▶ **Always lubricate the cutting blade with protective spray before use.**

Symbols

The following symbols are important for reading and understanding the operating instructions. Please take note of the symbols and their meaning. The correct interpretation of the symbols will help you to use the machine in a better and safer manner.

Symbol	Meaning
	Wear protective gloves
	Wear eye protection.
	Movement direction
I	Switching On
O	Switching Off
	Permitted action
	Prohibited action
	Accessories

Intended Use

The machine is intended for cutting and trimming hedges and bushes in domestic use.

Technical Data

Cordless Hedgecutter		AHS 35-15 LI	AHS 45-15 LI
Article number		3 600 H49 B..	3 600 H49 A..
No-load stroke rate	min ⁻¹	2400	2400
Cutting length	mm	350	450
Tooth opening	mm	15	15
Weight according to EPTA-Procedure 01/2003	kg	1.9	2.0
Serial number	See serial number (type plate) on the machine		
Battery		Li-Ion	Li-Ion
Article number		2 607 336 909 2 607 336 759	2 607 336 909 2 607 336 759
Rated voltage	V	10.8	10.8
Capacity	Ah	1.5	1.5
Number of battery cells		3	3
Run time per battery charge, max.	min	50	50
Battery Charger		AL 1105 CV	AL 1105 CV
Article number	EU UK	2 607 225 649 2 607 225 651	2 607 225 649 2 607 225 651
Charging current	mA	500	500
Allowable charging temperature range	°C	0 45	0 45
Charging period (battery discharged)	min	180	180
Weight according to EPTA-Procedure 01/2003	kg	0.3	0.3
Protection class		□ / II	□ / II
Battery Charger		AL 1115 CV	AL 1115 CV
Article number	EU UK AU	2 607 225 513 2 607 225 515 2 607 225 517	2 607 225 513 2 607 225 515 2 607 225 517
Charging current	mA	1500	1500
Allowable charging temperature range	°C	0 45	0 45
Charging period (battery discharged)	min	63	63
Weight according to EPTA-Procedure 01/2003	kg	0.3	0.3
Protection class		□ / II	□ / II

Noise/Vibration Information

Measured sound values determined according to EN 60745.

Typically the A-weighted noise levels of the product are:
Sound pressure level 66 dB(A); sound power level 87 dB(A).
Uncertainty K = 3 dB.

Wear hearing protection!

Vibration total values a_h (triax vector sum) and uncertainty K determined according to EN 60745:
 $a_h < 2.5 \text{ m/s}^2$, $K = 1.5 \text{ m/s}^2$.

The vibration level given in this information sheet has been measured in accordance with a standardised test given in EN 60745 and may be used to compare one tool with another. It may be used for a preliminary assessment of exposure. The declared vibration emission level represents the main applications of the tool. However if the tool is used for different applications, with different accessories or insertion tools or is poorly maintained, the vibration emission may differ. This may significantly increase the exposure level over the total working period.

6 | English

An estimation of the level of exposure to vibration should also take into account the times when the tool is switched off or when it is running but not actually doing the job. This may significantly reduce the exposure level over the total working period.

Identify additional safety measures to protect the operator from the effects of vibration such as: maintain the tool and the accessories, keep the hands warm, organisation of work patterns.

Declaration of Conformity



We declare under our sole responsibility that the product described under "Technical data" is in conformity with the following standards or standardization documents: EN 60745 according to the provisions of the directives 2011/65/EU, 2004/108/EC, 2006/42/EC, 2000/14/EC, 2000/14/EC: Guaranteed sound power level 90 dB(A). Conformity assessment procedure according to Annex V.

Equipment category: 2S

Technical file (2006/42/EC, 2000/14/EC) at:
Bosch Lawn and Garden Ltd., PT-LG/ENS23,
Stowmarket, Suffolk IP14 1EY, England

Henk Becker
Executive Vice President
Engineering

Helmut Heinzlmann
Head of Product Certification
PT/ETM9

 i.v. 

Robert Bosch GmbH, Power Tools Division
D-70745 Leinfelden-Echterdingen
29.01.2014

Mounting and Operation

Action	Figure
Delivery Scope	1
Inserting the Battery	2
Starting	3
Stopping	4
Working Advice	5
Blade Maintenance	6
Storage and Transport	6
Selecting Accessories	7

Battery Charging

Charging Procedure

The charging procedure starts as soon as the mains plug of the battery charger is plugged into the socket outlet and the battery is inserted into the charging compartment.

Note: The charging procedure is only possible when the battery temperature is within the allowable charging temperature range, see Section "Technical Data".

Flashing Battery Charge Indicator



The charging procedure is signalled by a **flashing** battery charge indicator.

Continuous Lighting of the Battery Charge Indicator



Continuous lighting of the battery charge indicator indicates that the battery is fully charged **or** that the temperature of the battery is not within

the allowable charging temperature range, and cannot be charged for this reason. The battery is charged as soon as the allowable charging temperature range is reached.

When the battery is not inserted, **continuous lighting** of the battery charge indicator indicates that the mains plug is inserted in the socket and that the battery charger is ready for operation.

Working Advice

► **Hold the garden product away from yourself. Stand in a secure and stable position. When storing the product, do not store it hanging on the front handle or switch.**

Anti Blocking

If the blade stalls on a tough material, the load of the motor increases. The intelligent micro-electronics senses this overload condition and repeatedly reverses the motor, in order to prevent stalling and to cut the material through.

This audible reversing cut action continues for up to 3 s.

After cutting through, the garden product continues in its normal mode, or in case the overload condition continues the blades automatically stop in the open position (e. g. in case a piece of metal fence accidentally blocks the garden product).

Troubleshooting



Problem	Possible Cause	Corrective Action
Hedgecutter does not operate	Battery discharged	Recharge battery; also see "Battery Charging"
	Safety switch not activated correctly	see "Mounting and Operation" for correct use
Hedgecutter operates intermittently	Internal wiring of garden product damaged	Contact Service Agent
	On/Off switch defective	Contact Service Agent
	Motor reverses repeatedly then stalls after 3 s.	see "Working Advice" (Anti Blocking)
Motor runs but blades remain stationary	Internal fault	Contact Service Agent
Cutting blade hot	Cutting blade blunt	Have blade sharpened
	Cutting blade has dents	Have blade inspected/overhauled
	Too much friction, due to lack of lubricant	Apply lubricant spray (1 609 200 399)
Blade will not move	Battery discharged	Recharge battery; also see "Battery Charging"
	Garden product defective	Contact Service Agent
Excessive vibrations/noise	Garden product defective	Contact Service Agent
Cutting time per battery charge too low	Too much friction, due to lack of lubricant	Apply lubricant spray
	Blade needs cleaning	Clean blade
	Battery not fully charged	Recharge battery; also see "Battery Charging"
Continuous lighting of the battery charge indicator No charging procedure possible	Battery not (properly) inserted	Properly insert battery into battery charger
	Battery contacts contaminated	Clean the battery contacts (e. g. by inserting and removing the battery several times) or replace the battery
	Battery pack defective	Replace the battery
The blades are running slow or the anti blocking feature is not functioning	Battery discharged	Recharge battery; also see "Battery Charging"
	Battery stored outside of battery temperature	Allow battery to warm naturally to room temperature (within battery operating temperature 0 - 45 °C)
Battery charge indicator does not light up	Mains plug of battery charger not plugged in (properly)	Insert mains plug (fully) into the socket outlet
	Socket outlet, mains cable or battery charger defective	Check the mains voltage; have the battery charger checked by an authorised after-sales service agent for Bosch power tools

After-sales Service and Application Service

www.bosch-garden.com

In all correspondence and spare parts order, please always include the 10-digit article number given on the type plate of the machine.

8 | English

Great Britain

Robert Bosch Ltd. (B.S.C.)
P.O. Box 98
Broadwater Park
North Orbital Road
Denham
Uxbridge
UB 9 5HJ

At www.bosch-pt.co.uk you can order spare parts or arrange the collection of a product in need of servicing or repair.

Tel. Service: (0844) 7360109

E-Mail: boschservicecentre@bosch.com

Ireland

Origo Ltd.
Unit 23 Magna Drive
Magna Business Park
City West
Dublin 24
Tel. Service: (01) 4666700
Fax: (01) 4666888

Australia, New Zealand and Pacific Islands

Robert Bosch Australia Pty. Ltd.
Power Tools
Locked Bag 66
Clayton South VIC 3169
Customer Contact Center
Inside Australia:
Phone: (01300) 307044
Fax: (01300) 307045
Inside New Zealand:
Phone: (0800) 543353
Fax: (0800) 428570
Outside AU and NZ:
Phone: +61 3 95415555
www.bosch.com.au

Republic of South Africa**Customer service**

Hotline: (011) 6519600

Gauteng BSC Service Centre

35 Roper Street, New Centre
Johannesburg
Tel.: (011) 4939375
Fax: (011) 4930126
E-Mail: bsctools@icon.co.za

KZN BSC Service Centre

Unit E, Almar Centre
143 Crompton Street
Pinetown
Tel.: (031) 7012120
Fax: (031) 7012446
E-Mail: bsc.dur@za.bosch.com

Western Cape BSC Service Centre

Democracy Way, Prosperity Park
Milnerton
Tel.: (021) 5512577
Fax: (021) 5513223
E-Mail: bsc@zsd.co.za

Bosch Headquarters

Midrand, Gauteng
Tel.: (011) 6519600
Fax: (011) 6519880
E-Mail: rbsa-hq.pts@za.bosch.com

Transport

The contained lithium-ion batteries are subject to the Dangerous Goods Legislation requirements. The user can transport the batteries by road without further requirements.

When being transported by third parties (e.g.: air transport or forwarding agency), special requirements on packaging and labelling must be observed. For preparation of the item being shipped, consulting an expert for hazardous material is required.

Dispatch batteries only when the housing is undamaged.

Tape or mask off open contacts and pack up the battery in such a manner that it cannot move around in the packaging. Please also observe possibly more detailed national regulations.

Disposal

Do not dispose of garden products, battery chargers and batteries/rechargeable batteries into household waste!

Only for EC countries:

According to the European law 2012/19/EU, electrical and electronic equipments that are no longer usable, and according to the European law 2006/66/EC, defective or used battery packs/batteries, must be collected separately and disposed of in an environmentally correct manner.

Batteries no longer suitable for use can be directly returned at:

Great Britain

Robert Bosch Ltd. (B.S.C.)
P.O. Box 98
Broadwater Park
North Orbital Road
Denham
Uxbridge
UB 9 5HJ

At www.bosch-pt.co.uk you can order spare parts or arrange the collection of a product in need of servicing or repair.

Tel. Service: (0844) 7360109

E-Mail: boschservicecentre@bosch.com

Battery packs/batteries:**Li-Ion:**

Please observe the instructions in section "Transport".

Subject to change without notice.

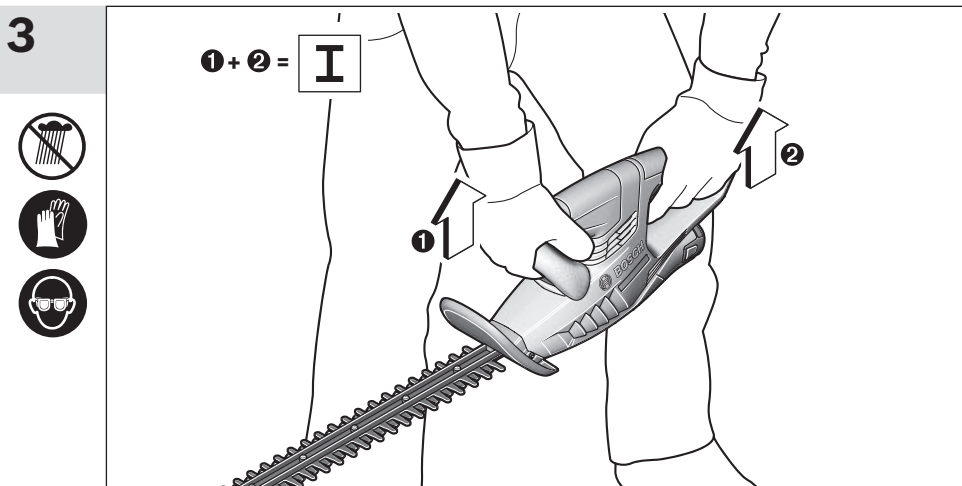
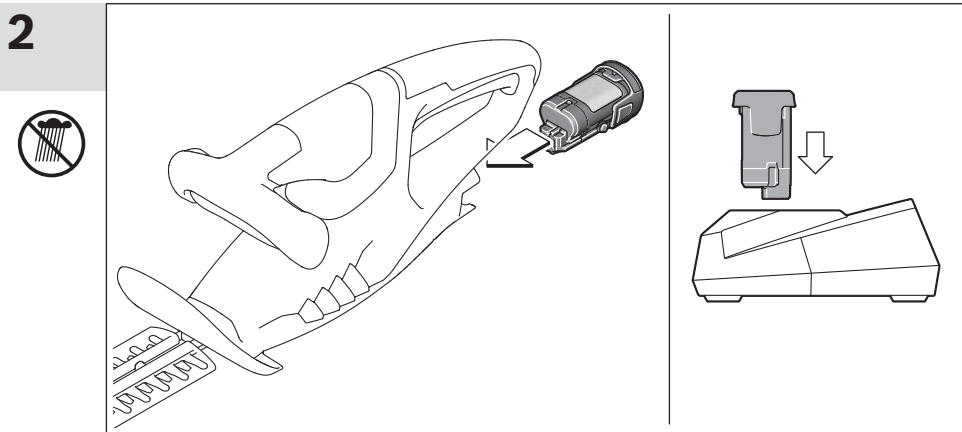
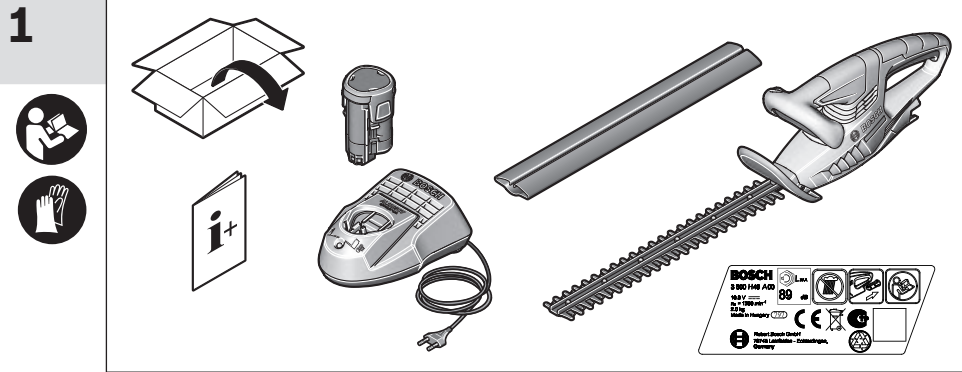

10 |

4

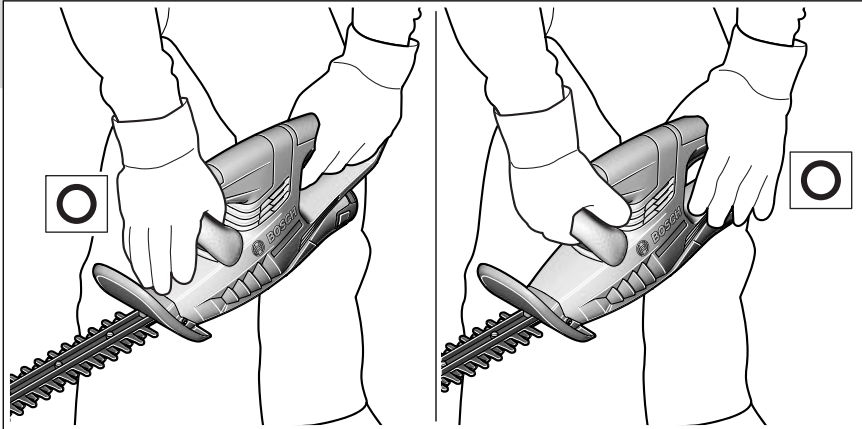

5

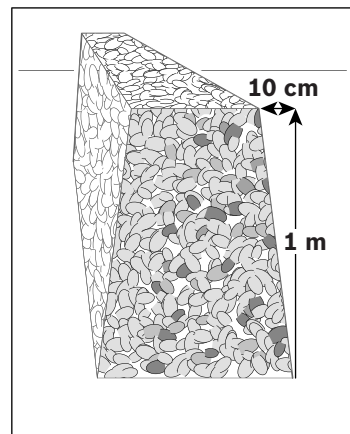
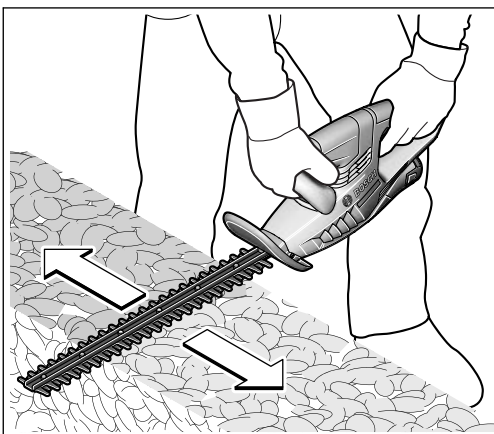
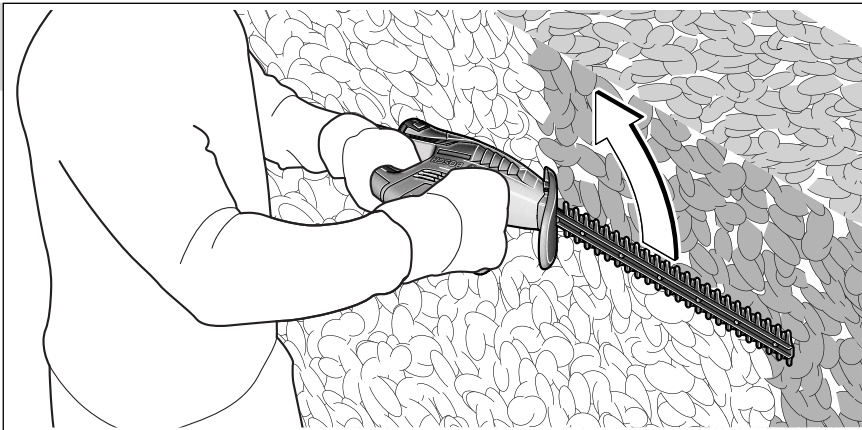

6

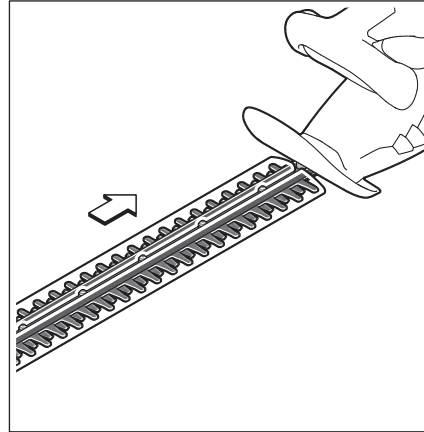
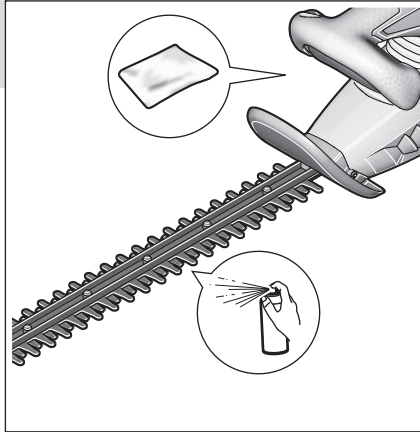

7



1 609 200 399



F 016 800 178

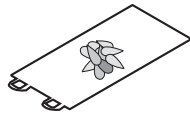

F 016 800 055



F 016 800 292

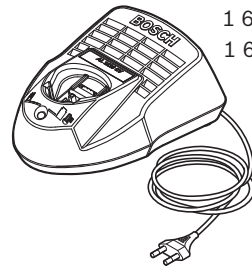

1 600 Z00 03P (EU)
1 600 Z00 03R (UK)



1 600 Z00 03K